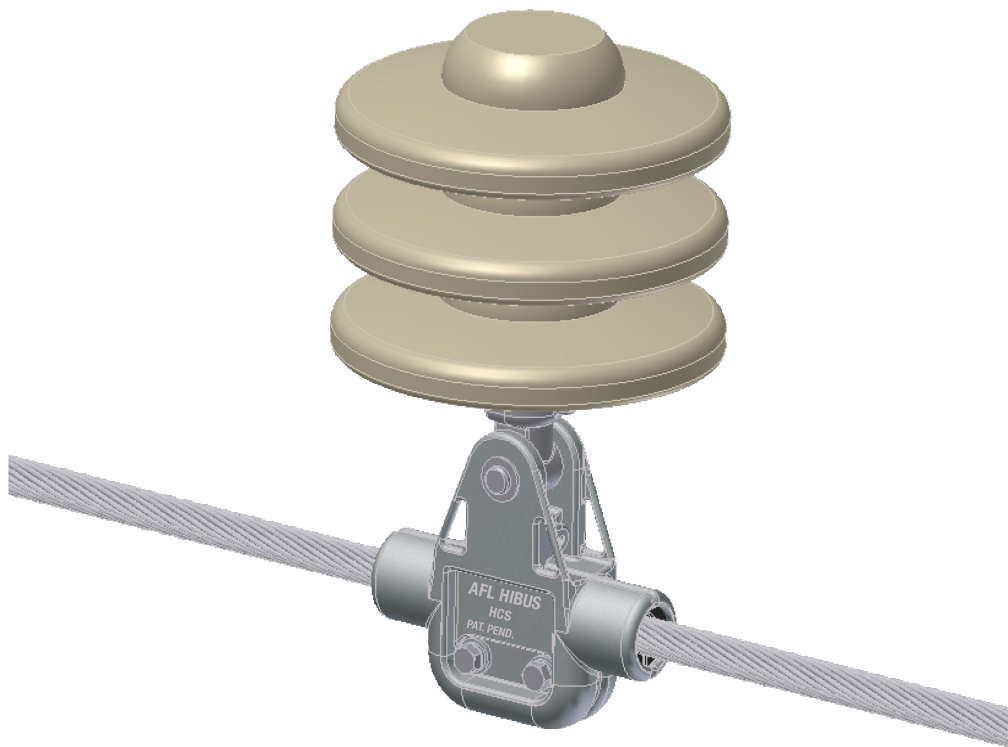

Installation Procedure for HIBUS[®] HCS Series Conductor Suspension Clamp

(Assembly Reference B9409)

**NOTE:**

EXCEPT AS MAY BE OTHERWISE PROVIDED BY CONTRACT, THESE DRAWINGS AND/OR SPECIFICATIONS ARE THE PROPERTY OF AFL, ARE ISSUED IN STRICT CONFIDENCE, AND SHALL NOT BE REPRODUCED OR COPIED OR USED AS THE BASIS FOR MANUFACTURE OR SALE OF PRODUCT WITHOUT PERMISSION.

Preparation

Prior to making connection, the conductor and accessory must be clean. Check accessory groove(s) and bushings for foreign particles, removing if present.

Installation

HIBUS Conductor Suspension Clamp Assembly Installation Parts List:

ITEM	DESCRIPTION	MATERIAL	QTY
-	HIBUS Conductor Suspension Assembly	-	-
1-1	HIBUS Conductor Suspension Clamp - RH	Aluminum	1
1-2	HIBUS Conductor Suspension Clamp - LH	Aluminum	1
2	1/2" Clamping Bolt	SS	2
3	1/2" Belleville Spring Washer	SS	2
4	1/2" Flat Washer	SS	2
5	Bushings	Elastomer	4
6	O-Rings – Bolt Retainer	BUNA-N	2
7	5/8" Attachment Clevis Pin	Galv. Steel	1
8	5/8" Flat Washer - optional	Galv. Steel	2
9	Cotter Pin	SS	1
-	Socket Eye – Type SA – supplied by Customer	-	-

- Remove attachment hardware from HIBUS Suspension Clamp as shown in **Fig. 1**.

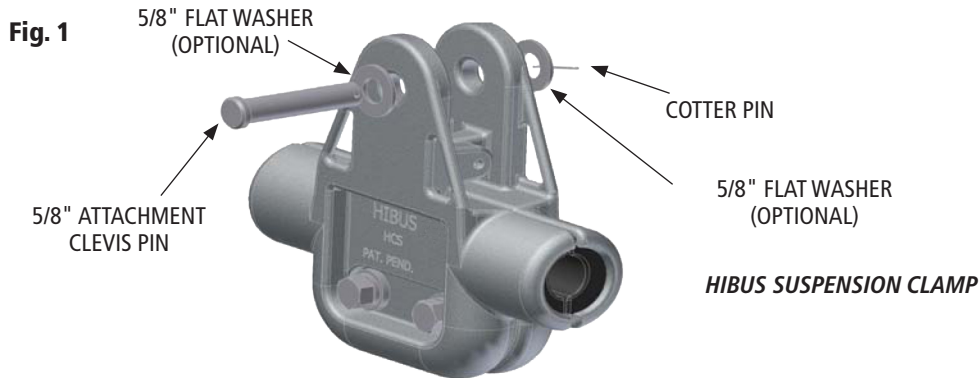

- Loosen Clamping Bolts (items 2, 3, 4 and 6) to allow the HIBUS Suspension Clamp to hinge open. Squeeze the "ears" (top of the HIBUS Suspension Clamp) to open as shown in **Fig. 2**.

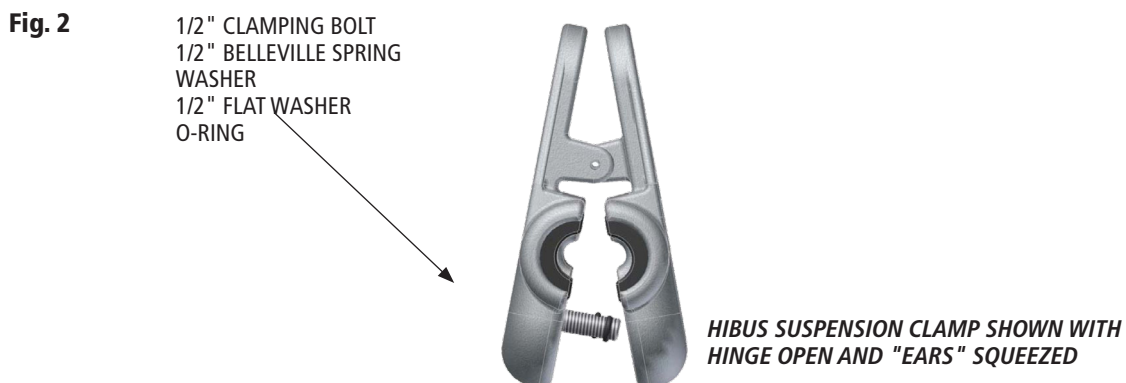

3. Position HIBUS Suspension Clamp to align the groove bushings to encapsulate conductor as shown in **Fig. 3-1**. Squeeze the bottom of the HIBUS Suspension Clamp to close the clamp around the conductor as shown in **Fig. 3-2**. Visually inspect Suspension Clamp to ensure that the assembly [groove–bushings (both ends)] and conductor are not cocked or misaligned.
4. Install Clamping Bolts (items 2, 3, 4, and 6) into the HIBUS Suspension Clamp. Hand tighten mounting hardware to engage threads with the Suspension Clamp. Alternate tightening to ensure HIBUS Conductor Suspension Clamp is not misaligned as shown in **Fig. 3-2**.

Fig. 3-1

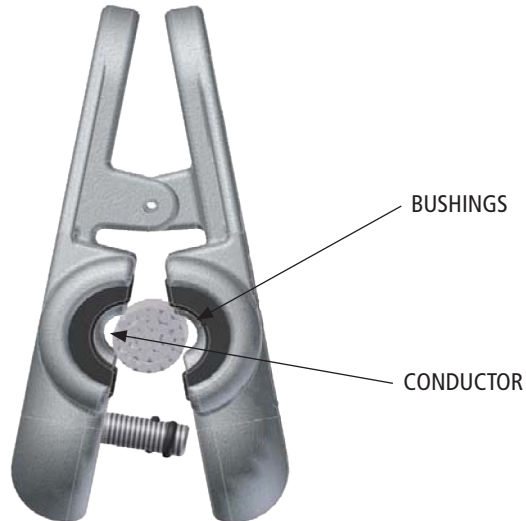

HIBUS SUSPENSION CLAMP SHOWN IN POSITION TO ENCAPSULATE CONDUCTOR

Fig. 3-2

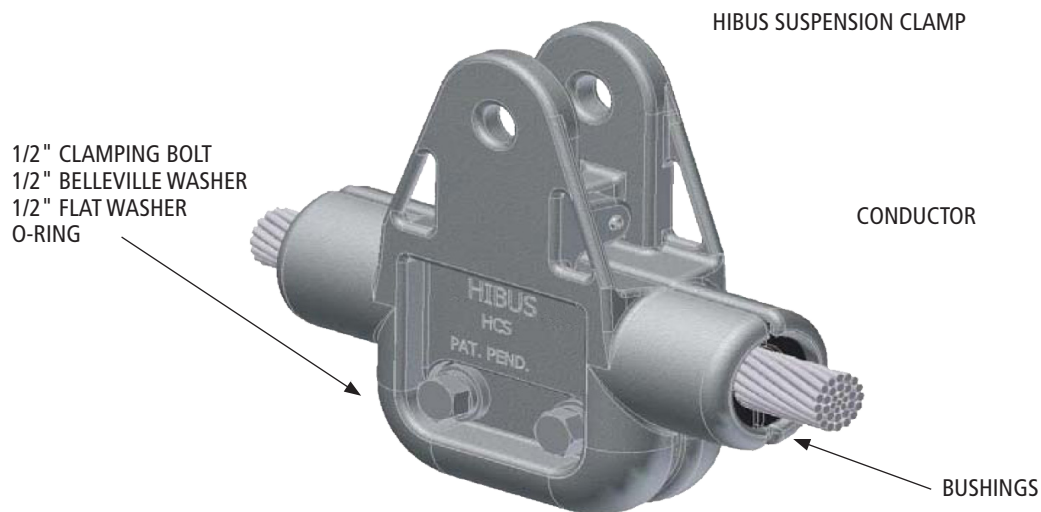

HIBUS SUSPENSION CLAMP SHOWN INSTALLED ON CONDUCTOR WITH MOUNTING HARDWARE INSTALLED

5. Torque Clamping Bolts (item 2) on HIBUS Conductor Suspension Clamp in 5 ft-lb. increments alternating the tightening until 40 ft-lbs. have been achieved on each.
6. Install HIBUS Suspension Clamp Assembly to Socket Eye with Attachment Hardware (items 7-9) as shown in **Fig. 4-1**.
NOTE: When an alternate bolt, nut, and cotter pin arrangement is used for attachment instead of the standard clevis pin and cotter pin, DO NOT apply a wrench to the nut. The cotter pin should be able to be installed into the bolt when the nut is only finger tight.
7. Make final visual inspection on HIBUS Conductor Suspension Clamp to ensure that the assembly [groove-bushings (both ends)] and conductor are not cocked or misaligned, but properly seated.

Fig. 4-1

- 5/8" ATTACHMENT CLEVIS PIN
- 5/8" FLAT WASHER [BOTH SIDES]
(OPTIONAL HARDWARE)
- COTTER PIN

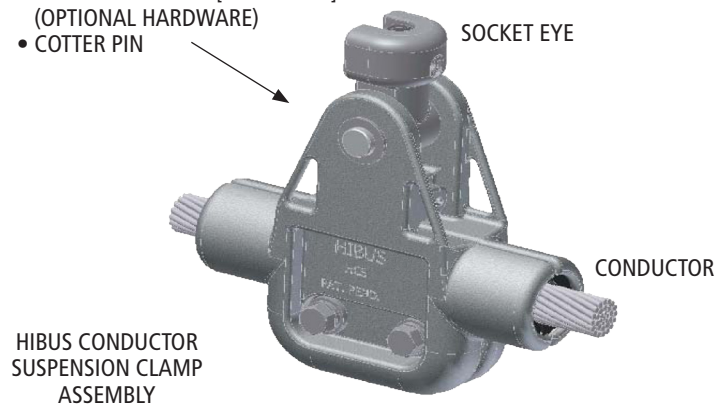

HIBUS CONDUCTOR SUSPENSION CLAMP ASSEMBLY AS INSTALLED. NOTE: SOCKET EYE—TYPE SA SHOWN FOR INSTALLATION ONLY—CUSTOMER SUPPLIED HARDWARE.