

AFL Filler Compound (AFC) Required for Compression Accessories

CATALOG SERIES	4500		4600		5000 18000		5100 5600 5800		5200 5300 5500*		5400* 5700		7000 19300		7100 7200		7600 7700	
	LBS	G	LBS	G	LBS	G	LBS	G	LBS	G	LBS	G	LBS	G	LBS	G	LBS	G
71	—	—	—	—	.01	5	—	—	—	—	—	—	.01	5	—	—	—	—
72	—	—	—	—	.01	5	.01	5	—	—	—	—	.01	5	—	—	—	—
73	—	—	—	—	.02	9	.01	5	—	—	—	—	.02	9	—	—	—	—
74	—	—	—	—	.03	14	.02	9	.03	14	—	—	.03	14	.02	9	—	—
75	—	—	—	—	.04	18	.02	9	.05	23	—	—	.05	23	.03	14	—	—
76	.10	45	.10	45	.05	23	.02	9	.07	32	—	—	.07	37	.04	18	—	—
06	—	—	—	—	—	—	.02	9	—	—	—	—	—	—	—	—	—	—
09	—	—	—	—	.03	14	.02	9	—	—	—	—	—	—	—	—	—	—
10	.20	91	—	—	—	—	—	—	—	—	—	—	—	—	—	—	—	—
11	—	—	—	—	—	—	.03	14	—	—	—	—	—	—	—	—	—	—
12	.20	91	—	—	—	—	.03	14	—	—	—	—	—	—	—	—	.01	5
13	—	—	—	—	—	—	.03	14	—	—	—	—	—	—	—	—	.03	14
14	.30	136	—	—	—	—	—	—	—	—	—	—	—	—	—	—	.03	14
16	.50	227	—	—	—	—	—	—	—	—	—	—	—	—	—	—	—	—
18	.45	204	—	—	—	—	—	—	—	—	—	—	—	—	—	—	—	—
20	.30	136	.20	91	.07	32	.03	14	.08	36	.20	91	.08	36	.05	23	—	—
24	—	—	—	—	.09	41	.05	23	.13	59	.30	136	.13	59	.06	27	.04	18
27	—	—	.30	136	.12	54	.06	27	.19	86	.34	154	.17	86	.10	45	.08	36
30	—	—	.50	227	.19	86	.09	41	.32	145	.60	272	.32	145	.15	68	.11	50
34	—	—	.35	159	.25	113	.12	54	.41	186	.93	422	.41	186	.20	91	.32	145
36	—	—	—	—	.28	127	.15	68	.52	236	.96	435	.52	236	.26	118	—	—
38	—	—	—	—	.35	159	.17	77	.58	263	1.1	499	.58	263	.27	122	.27	122
40	—	—	—	—	.40	181	.20	91	.70	318	1.1	499	.70	318	.37	168	.37	168
42	—	—	—	—	.54	245	.24	109	.84	381	1.4	635	.84	381	.45	204	—	—
44	—	—	—	—	.67	304	.28	127	1.2	544	1.5	680	1.2	544	.55	249	—	—
48	—	—	—	—	.78	354	.32	145	1.6	590	1.6	726	1.3	590	.69	313	.62	281

AFL Filler Compound (AFC) Required for Compression Accessories (cont.)

CATALOG SERIES	8000		8100 8200		8300		8400		8600	
	LBS	G	LBS	G	LBS	G	LBS	G	LBS	G
71	—	—	—	—	—	—	—	—	—	—
72	.01	5	—	—	—	—	—	—	—	—
73	.02	9	—	—	—	—	—	—	—	—
74	.03	14	.02	9	—	—	—	—	—	—
75	.05	23	.04	18	—	—	—	—	—	—
76	.09	41	.07	32	—	—	—	—	.09	41
06	—	—	—	—	—	—	—	—	—	—
09	—	—	—	—	—	—	—	—	—	—
10	—	—	—	—	—	—	—	—	—	—
11	—	—	—	—	—	—	—	—	.03	14
12	—	—	—	—	—	—	—	—	.05	23
13	—	—	—	—	—	—	—	—	.06	27
14	—	—	—	—	—	—	—	—	—	—
16	—	—	—	—	—	—	—	—	—	—
18	—	—	—	—	—	—	—	—	—	—
20	.20	91	.14	64	.19	86	.27	122	—	—
24	.30	136	.22	100	.20	91	.26	118	—	—
27	.34	154	.34	154	—	—	—	—	—	—
30	.60	272	.47	213	.40	181	.57	259	—	—
34	.93	422	.56	254	—	—	—	—	—	—
36	.96	435	.62	281	—	—	—	—	—	—
38	1.1	499	.80	363	—	—	—	—	—	—
40	1.1	499	.90	408	—	—	—	—	—	—
42	1.4	635	1.1	499	—	—	—	—	—	—
44	1.5	680	1.2	544	—	—	—	—	—	—
48	1.6	726	.90	408	—	—	—	—	—	—

Notes:

The amount of AFC shown in the tabulation is for the purpose of estimating the amount of compound necessary for a construction project. The tabulated weights of filler compound shown in the above tables for the Catalog 5100, 5600, and 5800 terminals does not include sufficient quantity to fill the cavity area at the transition of the barrel and flat pad. If the terminal is installed with the barrel in the upright position, it is imperative that an additional quantity of AFC be used to fill the cavity area.

REFERENCE MATERIAL

NEMA Standard Pad Sizes for Standard Compression Accessories

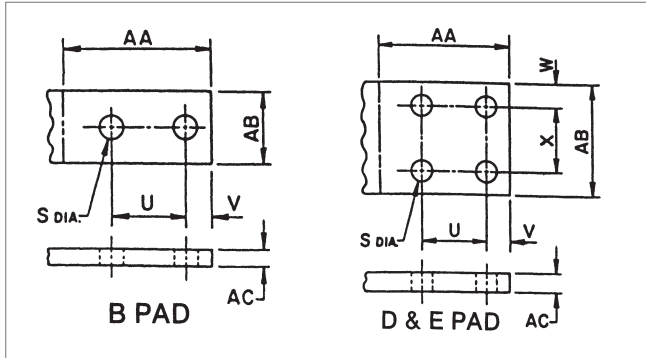

PAD LETTER	DIMENSIONS													
	S		U		V		W		X		AA		AB	
	IN	MM	IN	MM	IN	MM	IN	MM	IN	MM	IN	MM	IN	MM
B	0.56	14	1.75	44	0.62	16	--	--	--	--	3.50	89	1.75	44
D	0.56	14	1.75	44	0.62	16	0.62	16	1.75	44	3.50	89	3.00	76
E	0.56	14	1.75	44	1.12	29	1.12	29	1.75	44	4.50	114	4.00	102

CATALOG SERIES	4500 & 4600				5300				5700				7100, 7200, 8100, 8200,			
	AB		AC		AB		AC		AB		AC		AB		AC	
	IN	MM	IN	MM	IN	MM	IN	MM	IN	MM	IN	MM	IN	MM	IN	MM
74	—	—	—	—	1.75	44	△	△	—	—	—	—	1.75	44	0.50	13
75	—	—	—	—	1.75	44	0.44	11	—	—	—	—	2.25	57	0.50	13
76	2.25	57	0.38	10	1.75	44	0.50	13	—	—	—	—	2.25	57	0.50	13
11	—	—	—	—	—	—	—	—	—	—	—	—	—	—	—	—
12	—	—	—	—	—	—	—	—	—	—	—	—	—	—	—	—
13	—	—	—	—	—	—	—	—	—	—	—	—	—	—	—	—
14	—	—	—	—	—	—	—	—	—	—	—	—	—	—	—	—
20	2.25	57	0.38	10	1.75	44	0.50	13	1.75	44	0.50	13	2.25	57	0.50	13
24	—	—	—	—	1.75	44	0.50	13	1.75	44	0.50	13	2.25	57	0.50	13
27	2.25	57	0.38	10	3.00	76	0.62	16	3.00	76	0.62	16	3.00	76	0.62	16
30	2.38	60	0.38	10	3.00	76	0.62	16	3.00	76	0.62	16	3.00	76	0.62	16
34	3.50	89	0.62	16	3.00	76	0.62	16	3.00	76	0.62	16	3.00	76	0.62	16
36	—	—	—	—	3.00	76	0.62	16	3.00	76	0.62	16	3.00	76	0.62	16
38	—	—	—	—	3.00	76	0.62	16	3.00	76	0.62	16	3.00	76	0.62	16
40	—	—	—	—	3.00	76	0.62	16	3.00	76	0.62	16	4.00	102	0.75	19
42	—	—	—	—	4.00	102	0.75	19	4.00	102	0.75	19	4.00	102	0.75	19
44	—	—	—	—	4.00	102	0.75	19	4.00	102	0.75	19	4.00	102	0.75	19
48	—	—	—	—	4.00	102	0.75	19	4.00	102	0.75	19	4.00	102	0.75	19
74	—	—	—	—	—	—	—	—	—	—	—	—	—	—	—	—
75	—	—	—	—	—	—	—	—	—	—	—	—	—	—	—	—

△ 5374.0 - AC: .44 in (11 mm)
 5374.1 - AC: .50 in (13 mm)
 5374.2 - AC: .50 in (13 mm)

Notes:

1. If catalog number has "EHV" suffix, the pad will be furnished with rounded corners.
2. 15° terminal connectors and dead end tongues are finished on both sides.

REFERENCE MATERIAL

NEMA Standard Pad Sizes for Standard Compression Accessories (cont.)

CATALOG SERIES	4500 & 4600				5300				5700				7100, 7200, 8100, 8200,			
	AB		AC		AB		AC		AB		AC		AB		AC	
	IN	MM	IN	MM	IN	MM	IN	MM	IN	MM	IN	MM	IN	MM	IN	MM
76	—	—	—	—	—	—	—	—	—	—	—	—	2.25	57	0.38	10
11	—	—	—	—	—	—	—	—	—	—	—	—	1.75	44	0.38	10
12	2.25	57	0.38	10	2.25	57	0.38	10	—	—	—	—	2.25	57	0.38	10
13	2.25	57	0.38	10	2.25	57	0.38	10	—	—	—	—	2.25	57	0.38	10
14	2.25	57	0.50	13	2.25	57	0.50	13	—	—	—	—	—	—	—	—
20	—	—	—	—	—	—	—	—	2.25	57	0.50	13	—	—	—	—
24	2.25	57	0.50	13	2.25	57	0.50	13	2.25	57	0.50	13	—	—	—	—
27	3.00	76	0.50	13	3.00	76	0.50	13	—	—	—	—	—	—	—	—
30	3.00	76	0.62	16	3.00	76	0.50	13	2.62	67	0.62	16	—	—	—	—
34	3.00	76	0.62	16	3.00	76	0.50	13	—	—	—	—	—	—	—	—
36	—	—	—	—	—	—	—	—	—	—	—	—	—	—	—	—
38	3.00	76	0.62	16	3.00	76	*	*	—	—	—	—	—	—	—	—
40	4.00	102	0.75	19	4.00	102	0.75	19	—	—	—	—	—	—	—	—
42	—	—	—	—	—	—	—	—	—	—	—	—	—	—	—	—
44	4.00	102	0.75	19	4.00	102	0.75	19	—	—	—	—	—	—	—	—
48	4.00	102	0.75	19	4.00	102	0.75	19	—	—	—	—	—	—	—	—

* 7738.138 - AC: .62 in (16 mm)
 7738.150 - AC: .50 in (13 mm)

Recommended Tightening Torque for Bolts

Recommended tightening torque for aluminum bolts with Alumilite 205 finish and lubricant coating

BOLT DIAMETER	TORQUE	
	LBF-FT	N.M
INCH		
5/16	10	14
3/8	15	20
7/16	20	27
1/2	25	34
5/8	40	54
3/4	60	81

Recommended tightening torque for galvanized steel bolts with lubricant coating

BOLT DIAMETER	TORQUE	
	LBF-FT	N.M
INCH		
5/16	15	20
3/8	25	34
1/2	40	54
5/8	60	81
3/4	75	102

REFERENCE MATERIAL

Steel Dead End Dimensions for Standard Compression Accessories

9000 Series Eyes

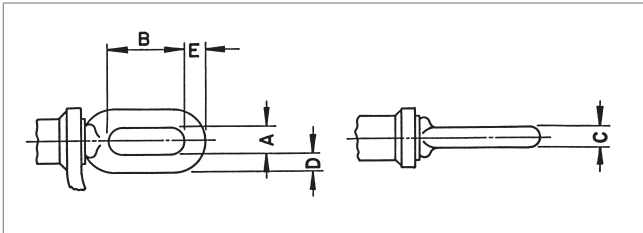

EYE CATALOG SERIES NUMBER	DIMENSIONS									
	A		B		C		D		E	
	IN	MM	IN	MM	IN	MM	IN	MM	IN	MM
9000	0.88	22	2.50	64	0.47	12	0.47	12	0.59	15
9100	0.88	22	2.50	64	0.62	16	0.62	16	0.69	18
9200	0.88	22	2.50	64	0.69	18	0.62	16	0.81	21
9300	1.25	32	2.69	68	0.75	19	0.69	18	0.88	22
9400	1.25	32	2.69	68	0.75	19	0.69	18	0.94	24
E9500	1.25	32	2.62	67	0.78	20	0.78	20	0.91	23
E9600	1.25	32	2.62	67	0.88	22	0.88	22	1.00	25
E9700	1.25	32	2.62	67	1.00	25	1.00	25	1.12	28
E9800	1.31	33	2.62	67	1.00	25	0.97	25	1.25	32

100 Series - Clevis

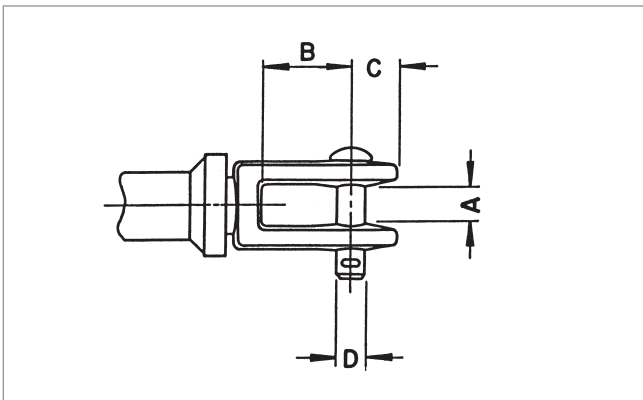

CLEVIS CATALOG SERIES NUMBER	DIMENSIONS							
	A		B		C		D	
	IN	MM	IN	MM	IN	MM	IN	MM
A100X	0.72	18	1.62	41	0.75	19	0.62	16
A101X	0.84	21	2.06	52	1.00	25	0.62	16
A102X	0.84	21	2.06	52	1.00	25	0.62	16
A103X	0.84	21	2.06	52	1.00	25	0.62	16

REFERENCE MATERIAL

Steel Dead End Dimensions for Standard Compression Accessories

C6000 Series - Adjustable Clevis

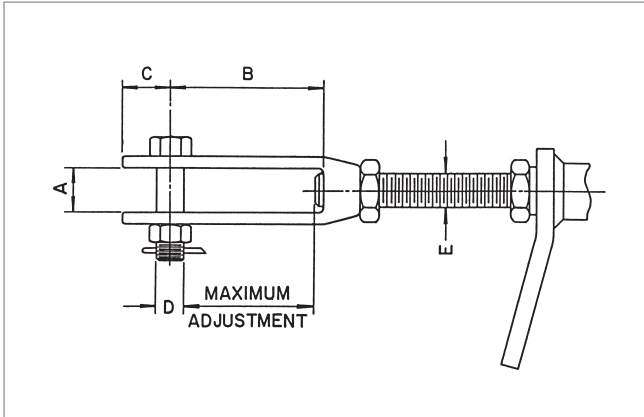

CLEVIS CATALOG SERIES NUMBER	DIMENSIONS										MAXIMUM ADJUSTMENT	
	A		B		C		D		E	IN	MM	
	IN	MM	IN	MM	IN	MM	IN	MM				
C6100	0.88	22	4.00	102	1.25	32	0.62	16	3/4-10 UNC	3.38	86	
C6200	1.00	25	4.00	102	1.25	32	0.75	19	7/8-9 UNC	3.38	86	
C6300	1.38	35	5.00	127	1.50	38	1.00	25	1-8 UNC	4.25	108	
C6400	1.38	35	5.00	127	1.50	38	1.00	25	1 1/8-7 UNC	4.25	108	
C6500	1.38	35	5.00	127	1.50	38	1.00	25	1 1/4-7 UNC	4.25	108	
C6600	1.62	41	6.00	152	1.75	44	1.12	28	1 3/8-6 UNC	5.12	130	
C6700	1.62	41	6.00	152	1.75	44	1.12	28	1 1/2-6 UNC	5.12	130	
C6800	2.00	51	6.00	152	2.00	51	1.12	28	1 5/8-8 UNC	5.12	130	

REFERENCE MATERIAL