

Installation Instructions for OPGW Double Suspension Unit

1. Mark center of clamp location on cable with ink (not tape).
2. Install the armor rods on cable aligning center mark of armor rods with center mark on OPGW (per Step 1).
3. Mark centers of clamp locations on armor rods with ink (not tape). This distance is equal to 1/2 the dimension between attachment holes on the yoke plate.
4. Remove clamp clevis pin. Loosen, but do not remove clamp keeper bolts. Remove the clamp keepers (see Figure 1).

FIGURE 1

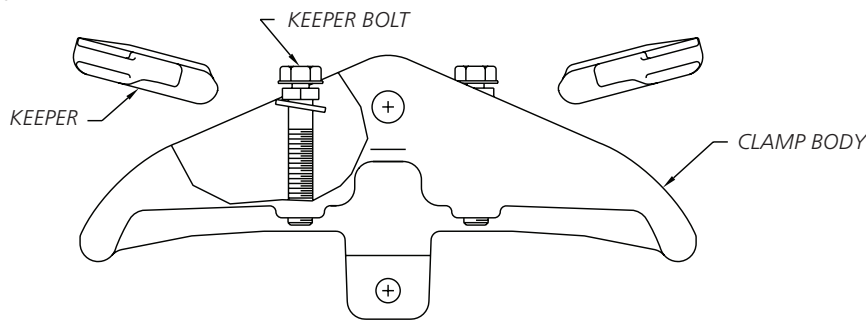

5. Place clamp body on OPGW and center clamp on one of the center marks (per Step 3).
6. Place keepers in clamp and slide keepers under keeper bolts.
7. Tighten keeper bolts finger tight and insure that keepers are not cocked on OPGW.
8. Tighten keeper bolts on each keeper in 5 ft-lb increments, alternating tightening to insure keepers are not cocked in clamp. Tighten until break-away bolt head shears off (see Figure 2).

FIGURE 2

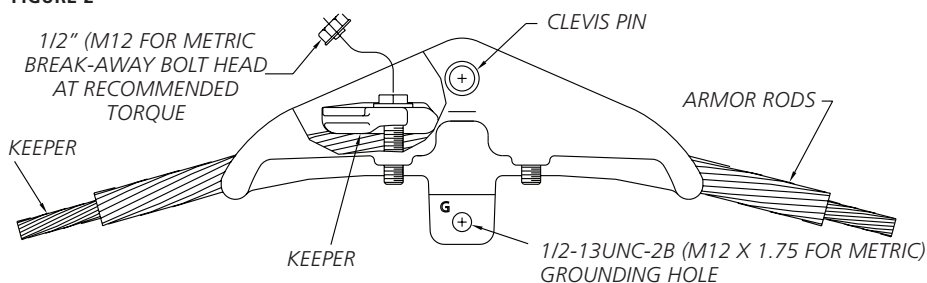

Installation Instructions for OPGW Double Suspension Unit (cont.)

9. Repeat steps 4 through 8 for the other clamp.
10. Attach clevis eye to clamp bodies with clevis pins and install cotter pins in clevis pins.
11. Attach clevis eyes to yoke plate.

FIGURE 3 - COMPLETED ASSEMBLY

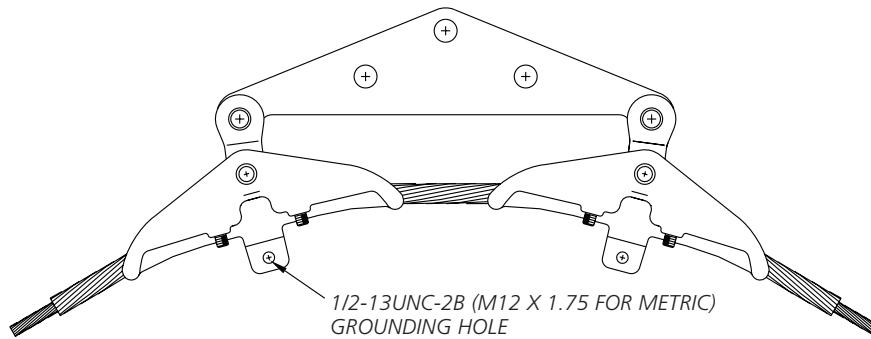

12. Attach completed assembly to tower attachment (see Figure 3).
13. Attach grounding lug to grounding pad (side marked "G") on bottom of suspension clamp (using 1/2"-13 thread tapped hole) if grounding is required.